

swissauto

Important notice:

By installing the Swissauto 250 engine on the kart, it is very important to control if the fixation points are fully plane. When the engine mount is positioned on a welding seem or another uneven part, distortions can rise when you seize the bloc.

In this case the unnecessary load on the crankcase of the engine(that does exist out of two parts) can lead to leaking of the jointing compound between the diagonal parts of the bloc. The result could be little oil sweating on that place.

To avoid this situation following should be altered (see the picture below):

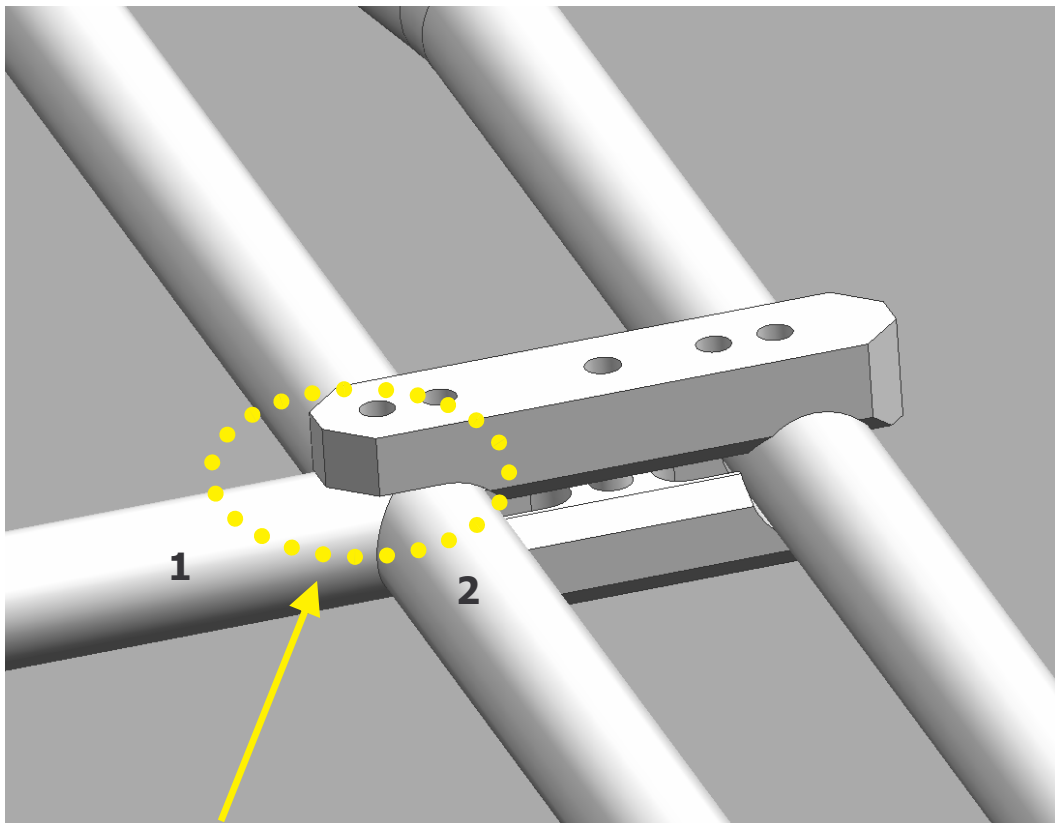

1. Welding seems that are too high should be removed.
2. When the diameter of the transversal tube (1) is larger then the one of the lateral tube (2), it is necessary to cut a part of the engine mount away.

It is a must to avoid that the rear engine mount of the engine is positioned on the transversal tube of the chassis !